



EN

# Quick Installation Guide

**Gigabit Switch, Managed, 250W,  
16x PoE, 4x SFP, 1000Mbps,  
Wall-/Rack Mounting, Desktop**

**IAR-7SE2016MMA**

## About Documents

This document is [Quick Installation Guide](#). It is intended for engineers or anyone who needs to install the product.

## Announcement



The information in this document is subject to change without notice.

The document is only used as operation guide, except for other promises. No warranties of any kind, either express or implied are made in relation to the description, information or suggestion or any other contents of the manual.

The images shown here are indicative only. If there is inconsistency between the image and the actual product, the actual product shall govern.

## Symbol Conventions

The symbols that may be found in this document are defined as follows.

Symbol	Description
 <b>DANGER</b>	Indicates a hazard with a high level of risk, which if not avoided, will result in death or serious injury.
 <b>WARNING</b>	Indicates a hazard with a medium or low level of risk, which if not avoided, could result in minor or moderate injury.
 <b>CAUTION</b>	Indicates a potentially hazardous situation, which if not avoided, could result in equipment damage, data loss, performance degradation, or unexpected results.

## Content

<b>1</b>	<b>Packing List</b> .....	<b>1</b>
<b>2</b>	<b>Product Introduction</b> .....	<b>2</b>
	2.1 Overview .....	2
	2.2 Hardware Introduction .....	2
<b>3</b>	<b>Installations</b> .....	<b>4</b>
	3.1 Safety Precaution .....	4
	3.2 Insatallation Steps .....	6
	3.2.1 Rack Mount .....	7
	3.2.2 Desktop Installation .....	8
	3.2.3 Wall Mount.....	8
	3.2.4 AC Power Cable Connection .....	9
<b>4</b>	<b>Specifications</b> .....	<b>10</b>

# 1 Packing List

Open the box of the product and carefully unpack it. The box should contain the following items. Please check before installation, if any missing, please contact your dealer immediately.

No.	Items	Quantity
1	Switch	1 pc
2	AC Power Cable	1 pc
3	Mounting Accessory	1 set
4	Quick Installation Guide	1 pc

# 2 Product Introduction

## 2.1 Overview

This series product is 16-Port/24-Port Gigabit PoE + 4-Port Gigabit SFP L2 Managed Ethernet Switch (250W).

This series switch provides 16/24 Gigabit Ethernet RJ-45 ports and 4 Gigabit SFP uplink ports. The switch meets IEEE 802.3af/at standard. All RJ-45 ports support Power-over-Ethernet (PoE+) and deliver up to 30W power per port.

The switch has extensive L2 management functions, such as 802.1Q VLAN, 802.1P QoS, STP/RSTP, Link aggregation, DHCP and PoE control. It can be easily managed via a WEB GUI (<http/https>), CLI (telnet/ssh/console) or SNMP.

This series contains two types:

- 16-Port Gigabit PoE + 4-Port Gigabit SFP L2 Managed Ethernet Switch (250W)  
(short for 16-Port PoE Switch)
- 24-Port Gigabit PoE + 4-Port Gigabit SFP L2 Managed Ethernet Switch (250W)  
(short for 16-Port PoE Switch)

## 2.2 Hardware Introduction

### Front Panel (16-Port PoE Switch)

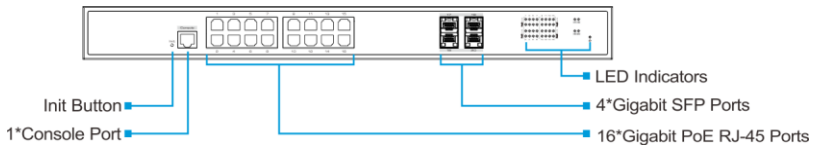

### Front Panel (24-Port PoE Switch)

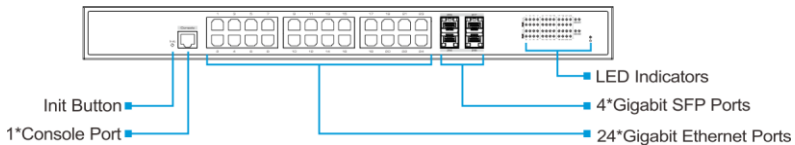

## Rear Panel (16-Port/24-Port PoE Switch)



### [Led Indicators Instructions](#)

Indicators		Status	Descriptions
PWR	Power Supply Indicator	On	The Main Power Supply is working.
		Off	The Main Power Supply is off.
Link	Port Link Indicators	On	The port is linking normally.
		Blink	The port is transmitting or receiving data.
		Off	The port links down.
PoE	Port PoE Indicators	On	The port is supplying PoE power normally.
		Off	The port stops supplying PoE power.

### [Console Port](#)

The device contains a serial RS-232 interface as the console port for local management interface. For the console port, a standard RJ-45 connector is used. Use a RS-232 cable (Sub-D9 to RJ-45) to connect the console port with the COM port of a PC.

Default configuration:

Data	Default value
Transfer rate	115200 bit/s
Flow control mode	Not support
Test mode	Not support
Stop bits	1
Data bits	8

## 3 Installations

### 3.1 Safety Precaution

To minimize the technically residual risk, it is imperative to obey the following rules. Read all the instructions before operation.

The Caution, Warning and Danger items in the document does not cover all the safety precautions that must be followed. They are only supplementary information.

When operating the device, obey the local safety regulations. The safety precautions provided in the documents are supplementary and shall be in compliance with the local safety regulations.

#### Operator

- Only qualified and skilled personnel can install, configure, and disassemble the device.
- Only the personnel authorized can operate the device.
- Any replacement or change to the device or parts of the device (including the software) must be done by qualified or authorized personnel.
- Any fault or error that might cause safety problems must be reported immediately to the person in charge.

#### Ground

For better protection performance, it is recommended as follows.

- Do not damage the ground conductor or operate the device in the absence of well installed ground conductor. Conduct the appropriate electrical inspection.
- When operating the unit, always make the ground connection first and disconnect it at the end.

#### Human Safety

- Do not operate the device or cables at lightning strikes.
- If the device is designed with optical port, do not look directly into the optical port to prevent the laser radiation from injuring your eyes.
- Do not wear jewelry or watches when you operate the device.

#### Equipment Safety

- Before operation, the device must be fixed securely on the floor or to other reliable objects, such as the desktop, the walls or the mounting racks.
- Do not block the ventilation while the device is running. Keep a minimum distance of 5 cm from the ventilation to the walls or the other objects that block the ventilation.
- Tighten the thumbscrews by using a tool after both initial installation and subsequent access to the panel.

## Inflammable Environment



### **DANGER**

Do not place the device in the environment that has inflammable and explosive air or fog. Do not perform any operation in this environment.

Operating the electrical device in inflammable environment can be fatal.

## Moisture Proof



### **WARNING**

Water or moisture in the equipment will damage the circuit of the equipment.

- The installation environment of the equipment must be strictly prohibited from water seepage, dripping, and condensation, otherwise it is necessary to install dehumidification equipment (such as air conditioners with dehumidification function, special dehumidifiers), etc.
- It is forbidden to operate the equipment under or near the water source, such as the sink, laundry room or other high humidity areas.
- It is forbidden to touch the device with wet hands.

## Dust Proof

- Install the equipment far away from sand and dust sources, such as coal mines, rural roads, and farmland, etc.
- It is forbidden to operate the device in a dense dust environment.

## Ventilation



### **WARNING**

Operating equipment will release heat. Please ensure that the environment where the equipment is installed is well ventilated to ensure the equipment operating normally.

- It is strictly forbidden to install the equipment near heat sources, such as stoves, heaters, etc.
- Ensure that the equipment installation environment has good air flow.
- If the equipment is designed with heat dissipation holes, it is strictly prohibited to block the heat dissipation hole of the device.



## 3.2 Installation Steps

This series switch supports 3 installation methods:

- Rack mount
- Desktop installation
- Wall mount



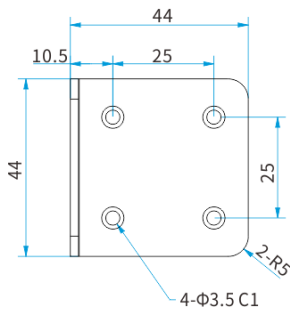
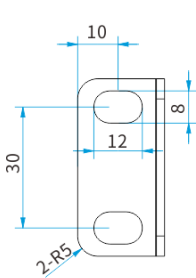
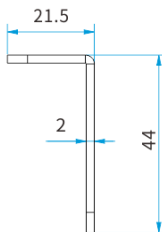
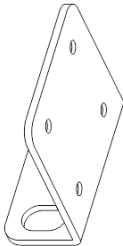
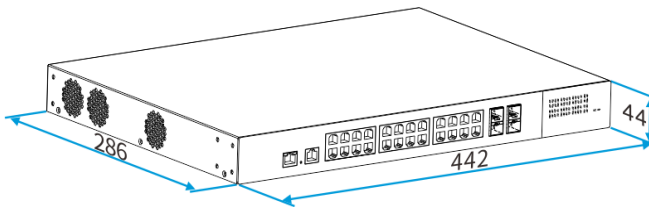

Following with the dimensions of the switch and its installation accessories. The two types are of the same dimensions. Here take 24-Port PoE Switch as example.

### Dimensions (mm)

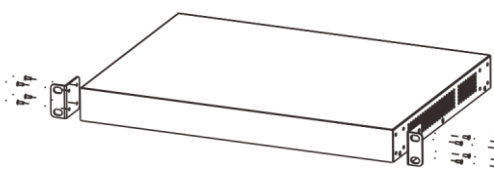

### 3.2.1 Rack Mount

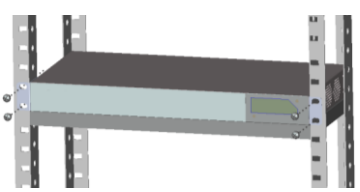
This series switch supports 19" rack-mounted installation. Following with the installation steps.

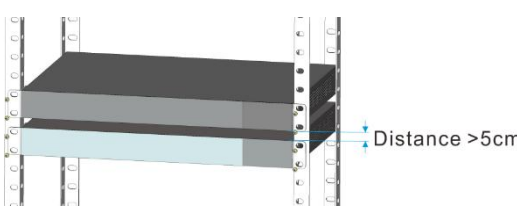
<b>Step 1: Fix the hangers on the side of the switch.</b> 	<b>Accessories</b>  2*  8*
<b>Step 2: Install the switch on the rack with screws in the package.</b> 	<b>Accessories</b>  4*
<b>Step 3: Continue to install other devices in the rack. The distance between the devices should be more than 5cm.</b> 	<b>Accessories</b> N/A





### 3.2.2 Desktop Installation

This series switch supports desktop installation. Users can put this product on clean, stable, grounded workbench. The installation steps are as below:

- Carefully put the device upside down, clean the grooves on the chassis backplane with soft cloth to make sure there is no oil or dust in it.
- Remove the stickers on the foot pad, paste the foot pad in backplane groove.
- Carefully put the device upright on the workbench.

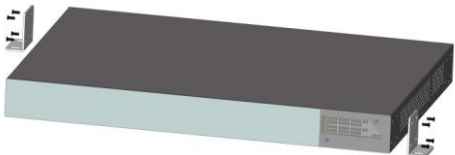
### 3.2.3 Wall Mount

This series switch supports wall-mounted installation. Users can put the switch on clean, steady vertical wall. Installation steps are as below:

<b>Step 1: Fix the hangers to the switch.</b> 	<b>Accessories</b>  2*  8*
<b>Step 2: Drill 4 holes on the wall where device is installed, then drive the rubber plug into the hole. Drive these screws into the hole for the rack and fix the product by aiming at the rubber plug.</b> 	<b>Accessories</b>  4*

### 3.2.4 AC Power Cable Connection

This series switch is equipped with one built-in power supply module.

Power supply module specifications:

Items	Specifications
<b>Power Input</b>	
Input Voltage	AC 100~240V 50/60Hz
Input Current	4A max
<b>Power Output</b>	
Output Voltage	54V DC
Output Current	5.2A max
Power Consumption	280.8W (Full load)

Connect the AC power cable to the switch through the power input interface. It is recommended to use the AC power cable provided in the package.

Connect the switch to AC power. Check if the power indicator turns on, which means the power is connected correctly.



#### **CAUTION**

- For better transmission performance, it is recommended to use Cat5 or better cables to connect the switch and powered devices.
- For better protection performance, it is recommended always to make the ground connection first and disconnect it at the end when operating the unit.
- Power on the system only after confirming that the wiring is correct, to avoid damage to the equipment.
- Read the user manual carefully before operating or maintaining the repeater to avoid misoperation.

The installation steps are finished.

## 4 Specifications

Items	16-Port PoE Switch	24-Port PoE Switch
Ethernet Ports		
Downlink Ports	16* 10/100/1000Base-T PoE RJ-45(Auto-MDI/MDI-X)	24*10/100/1000Base-T PoE RJ45 (Auto-MDI/MDI-X)
Uplink Ports	4*1000 Base-X SFP	
Console Port	1*RJ-45 to RS-232 console port(115200, 8, N, 1)	
PoE		
PoE Standard	IEEE 802.3af/at (PSE)	
PoE Power Supply Type	End-span	
PoE Pin Assignment	1/2(+), 3/6(-)	
PoE Power Output	54V DC	
PoE Power	30W for each port 230W max	30W for each port 230W max
Switch Property		
Standards	IEEE 802.3, IEEE 802.3u, IEEE 802.3ab, IEEE 802.3z, IEEE 802.3x, IEEE 802.1Q, IEEE 802.1p, IEEE 802.3ad, IEEE 802.1D, IEEE 802.1x	
Forwarding Modes	Store and Forward	
Packet Buffer	12MB	
MAC Table	16k, supported auto learning	
Switching Capacity	40Gbps / non-blocking	56Gbps / non-blocking
Packet Forwarding Rate	29.8Mpps	41.7Mpps
Jumbo Frame	10kB	
Power Supply		
Input Voltage	100~240VAC 50/60Hz	
Power Consumption	250W (Full load including PoE)	250W (Full load including PoE)
Reliability		
Surge Immunity	6kV, Standard: IEC61000-4-5	
ESD	6kV Contact discharge, 8kV Air discharge Standard: IEC61000-4-2	
MTBF	334959h	322194h
MTBF Standards	Telcordia SR-332, 25°C	

Operating Temperature	-10~50°C	
Storage Temperature	-40~85°C	
Operating Humidity	5%~95% (Non-condensation)	
Physical Parameters		
Led Indicators	1*PWR Indicator 16*Downlink Port Link Indicator 16*Downlink Port PoE Indicator 4*Uplink Port Link Indicator	1*PWR Indicator 24*Downlink Port Link Indicator 24*Downlink Port PoE Indicator 4*Uplink Port Link Indicator
Init Button	Short press to restart Long press >5s to initialize the system	
Dimension(W*D*H)	442mm*286mm*44mm	
Gross Weight	1900g±20g	2010g±20g
Net Weight	1620g±20g	1730g±20g
Material	Metal shell	
Installation	Rack mounted/desktop/wall mounted	
Certifications		
Certifications	CE, FCC	





eneo® is a registered trademark of  
VIDEOR E. Hartig GmbH  
Exclusive distribution through specialised  
trade channels only.

VIDEOR E. Hartig GmbH  
Carl-Zeiss-Straße 8  
63322 Rödermark/Germany  
Tel. +49 (0) 6074 / 888-0  
Fax +49 (0) 6074 / 888-100  
[www.videor.com](http://www.videor.com)  
[www.eneo-security.com](http://www.eneo-security.com)

Technical changes reserved

© Copyright by VIDEOR E. Hartig  
GmbH Version 03/2021