

# CM-22

Artikelnummer: 235562



Eckmontageadapter für Wandarm WB-24 und PTZ Dome Kamera INP-75A0033MIA

## Hauptmerkmale

## Spezifikationen

|                     |                           |
|---------------------|---------------------------|
| Andere              |                           |
| EAN/GTIN            | 4260229840580             |
| Abmessungen (HxBxT) | siehe Maßzeichnung        |
| Lieferumfang        | Montage Zubehör           |
| Serie               | eneo IN-Serie             |
| Gehäuse             | Aluminium                 |
| Farbe               | Pantone P 179-1, RAL 9003 |
| Schutzart           | IP64                      |
| Gewicht             | 2,4kg                     |
| Hersteller-Nummer   | 235562                    |

# CM-22

## Technical Drawing

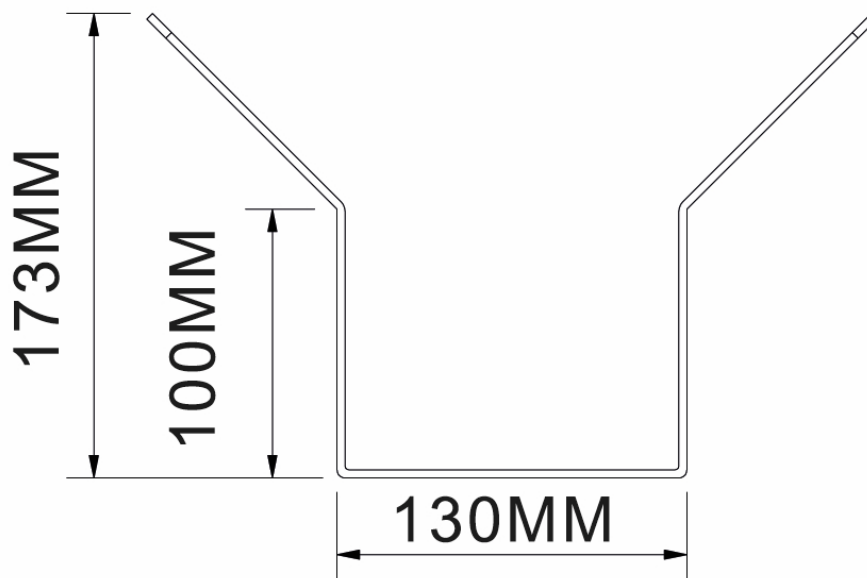
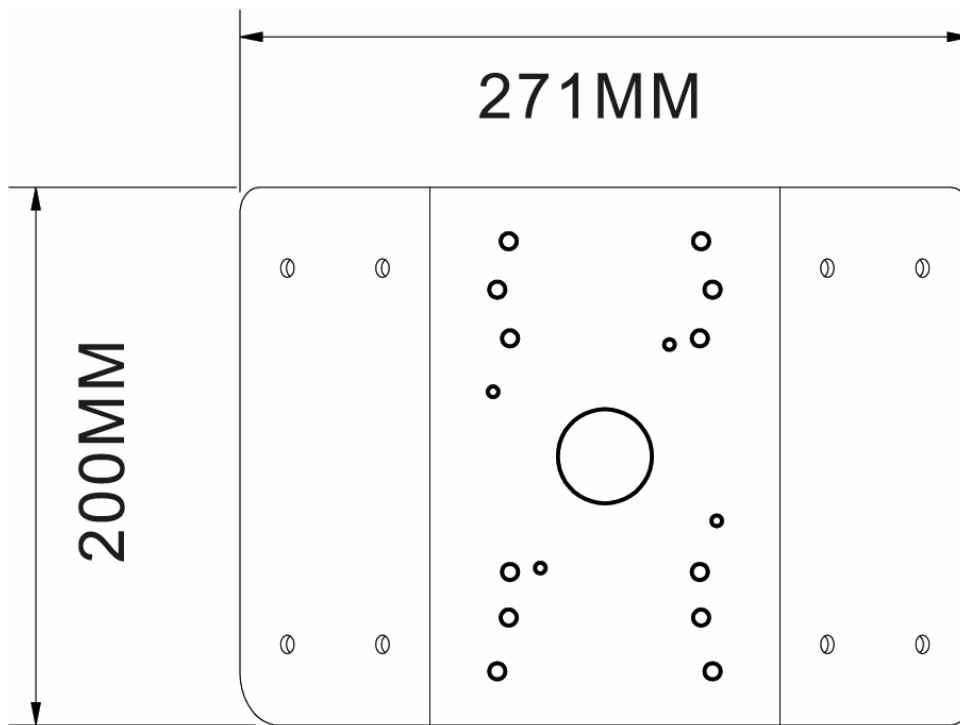

## Maße / Dimensions: mm



eneo is a registered trademark of  
VIDEOR E. Hartig GmbH  
Carl-Zeiss-Straße 8

63322 Rödermark, Deutschland

Phone: +49 6074 - 888 - 300  
Fax: +49 6074 - 888 - 100  
E-Mail: [info@eneo-security.com](mailto:info@eneo-security.com)  
Web: [www.eneo-security.com](http://www.eneo-security.com)

Stay informed and subscribe  
to the eneo newsletter

