

CM-22

Artikelnummer: 235562



Eckmontageadapter für Wandarm WB-24 und PTZ Dome Kamera INP-75A0033MIA

Hauptmerkmale

Spezifikationen

Andere	
EAN/GTIN	4260229840580
Abmessungen (HxBxT)	siehe Maßzeichnung
Lieferumfang	Montage Zubehör
Serie	eneo IN-Serie
Gehäuse	Aluminium
Farbe	Pantone P 179-1, RAL 9003
Schutzart	IP64
Gewicht	2,4kg
Hersteller-Nummer	235562

CM-22

Technical Drawing

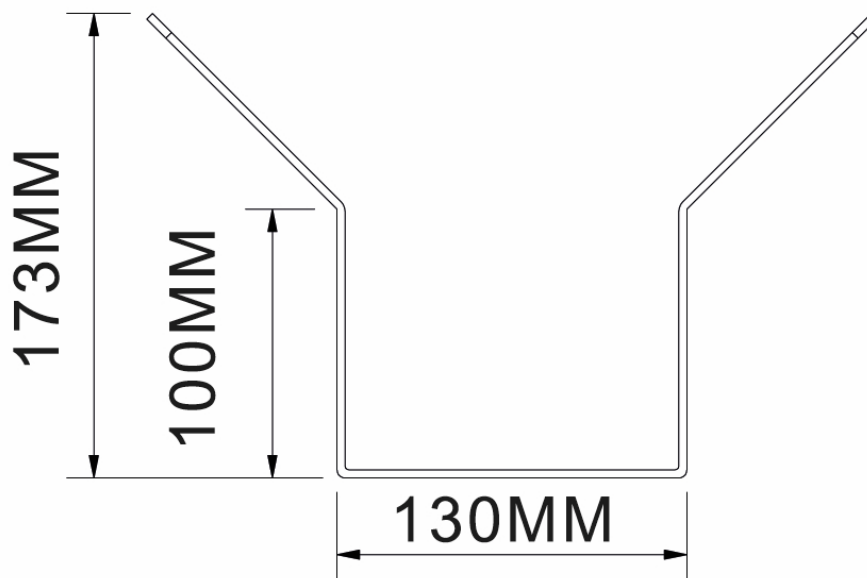
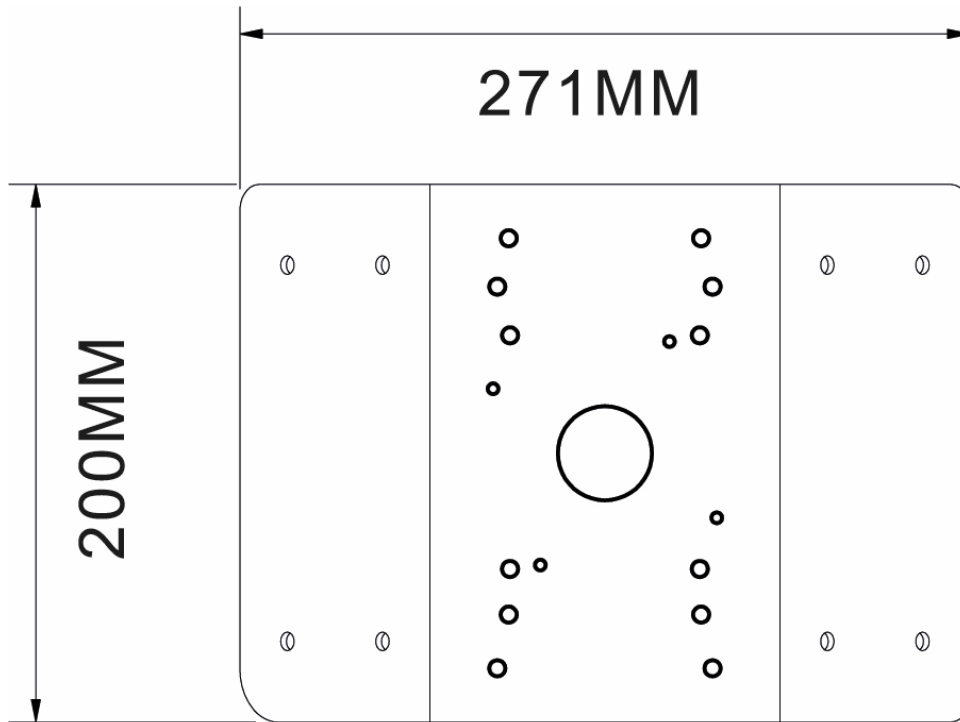

Maße / Dimensions: mm



eneo is a registered trademark of
VIDEOR E. Hartig GmbH
Carl-Zeiss-Straße 8

63322 Rödermark, Deutschland

Phone: +49 6074 - 888 - 300
Fax: +49 6074 - 888 - 100
E-Mail: info@eneo-security.com
Web: www.eneo-security.com

Stay informed and subscribe
to the eneo newsletter

